

*True Value*®

# LAWN CHIEF® OWNER'S GUIDE

## 5 HP REAR TINE TILLER

**Model  
21A-410-022**

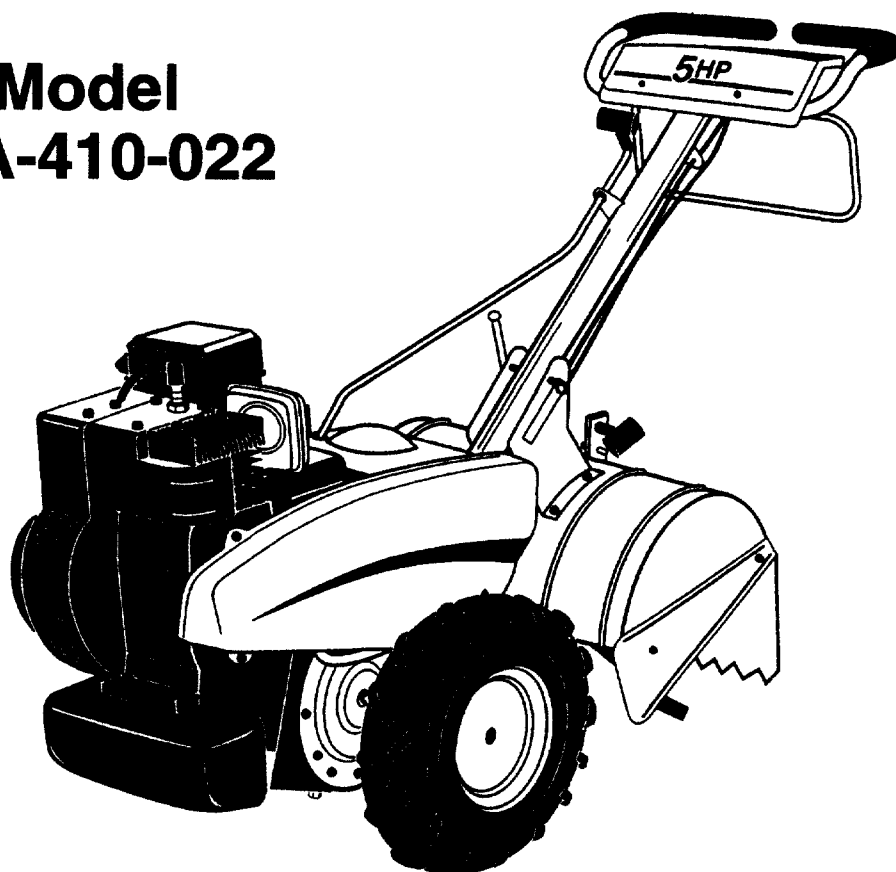

### **Important: Read Safety Rules and Instructions Carefully**

**WARNING:** This unit is equipped with an internal combustion engine and should not be used on or near any unimproved forest-covered, brush-covered or grass-covered land unless the engine's exhaust system is equipped with a spark arrester meeting applicable local or state laws (if any). If a spark arrester is used, it should be maintained in effective working order by the operator.

In the State of California the above is required by law (Section 4442 of the California Public Resources Code). Other states may have similar laws. Federal laws apply on federal lands. A spark arrester for the muffler is available through your nearest engine authorized service dealer or contact the service department, P.O. Box 368022, Cleveland, Ohio 44136-9722.

# IMPORTANT

## SAFE OPERATION PRACTICES



THIS SYMBOL POINTS OUT IMPORTANT SAFETY INSTRUCTIONS WHICH, IF NOT FOLLOWED, COULD ENDANGER THE PERSONAL SAFETY AND/OR PROPERTY OF YOURSELF AND OTHERS. READ AND FOLLOW ALL INSTRUCTIONS IN THIS MANUAL BEFORE ATTEMPTING TO OPERATE YOUR TILLER. FAILURE TO COMPLY WITH THESE INSTRUCTIONS MAY RESULT IN PERSONAL INJURY. WHEN YOU SEE THIS SYMBOL—  **HEED ITS WARNING.**



### **DANGER:**

**DANGER: Your tiller was built to be operated according to the rules for safe operation in this manual. As with any type of power equipment, carelessness or error on the part of the operator can result in serious injury. This tiller is capable of amputating hands and feet. Failure to observe the following safety instructions could result in serious injury or death.**



### **I. GENERAL OPERATION**

1. Read this owner's guide carefully in its entirety before attempting to assemble this machine. Read, understand, and follow all instructions on the machine and in the manual(s) before operation. Be completely familiar with the controls and the proper use of the machine before operating it. Keep this manual in a safe place for future and regular reference and for ordering replacement parts.
2. Your tiller is a powerful tool, not a plaything. Therefore, exercise extreme caution at all times. Your unit has been designed to perform one job: to till soil. Do not use it for any other purpose.
3. Never allow children under age 14 to operate the unit. Children 14 years and older should only operate the unit under close parental supervision. Only responsible individuals who are familiar with these rules of safe operation should be allowed to use your unit.
4. Do not operate tiller while under the influence of alcohol or drugs.
5. Keep the area of operation clear of all persons, particularly small children and pets. Stop the engine when they are in the vicinity of your tiller.
6. Wear sturdy, rough-soled work shoes and close fitting slacks and shirt. Shirt and slacks that cover the arms and legs and steel-toed shoes are recommended. Do not wear loose fitting clothes or jewelry and secure hair so it is above shoulder length. They can be caught in moving parts. Never operate a unit in bare feet, sandals or sneakers.
7. Operate tiller only in daylight or good artificial light.
8. Do not start tiller unless the shift lever (if provided) is in the neutral (N) position.
9. Do not allow anyone to stand or walk in front of tiller when starting or running engine.
10. Do not place feet or hands on or near the tines when starting the engine or while the engine is running.
11. Never attempt to make depth bar, tine width, cable, handle, or wheel adjustments while the engine is running.
12. Do not leave the tiller unattended with the engine running.
13. Before attempting to remove rocks, bricks and other objects from tines, stop the engine and be sure the tines have stopped completely. Disconnect the spark plug wire and move it away from the spark plug.
14. If your machine should start making an unusual noise or vibration, immediately stop the engine and allow the machine to come to a complete stop. Disconnect the spark plug wire and move it away from the spark plug. Take the following steps:
  - Inspect for damage.
  - Repair or replace any damaged parts.
  - Check for any loose parts and tighten to assure continued safe operation.
15. Muffler and engine become hot and can cause a burn. Do not touch.

16. Keep all shields, guards and safety devices in place and operating properly.
17. Use caution when tilling near fences, buildings and underground utilities. Rotating tines can cause damage or injury.
18. Do not operate engine if air cleaner or cover over carburetor air-intake is removed, except for adjustment. Removal of such parts could create a fire hazard.
19. Only use accessories approved for this machine by the manufacturer. Read, understand, and follow all instructions provided with the approved accessory.
20. If situations occur which are not covered by this manual, use care and good judgment. Contact your dealer for assistance.



### **II. CHILDREN**

Tragic accidents can occur if the operator is not alert to the presence of small children. Children are often attracted to the tilling activity. Never assume that children will remain where you last saw them.

1. Keep children out of the work area and under the watchful eye of a responsible adult other than the operator.
2. Be alert and turn the unit off if a child enters the area.
3. Never allow children under the age of 14 to operate the tiller.



### **III. SERVICE**

1. Use extreme care in handling gasoline and other fuels. They are extremely flammable and the vapors are explosive.
  - a. Store fuel and oil in approved containers, away from heat and open flame, and out of the reach of children. Check and add fuel before starting the engine. Never remove gas cap or add fuel while the engine is running. Allow engine to cool at least two minutes before refueling.
  - b. Replace gasoline cap securely and wipe off any spilled gasoline before starting the engine as it may cause a fire or explosion.
  - c. Extinguish all cigarettes, cigars, pipes and other sources of ignition.
  - d. Never refuel unit indoors because flammable vapors will accumulate in the area.
  - e. Never store the machine or fuel container inside where there is an open flame or spark such as a gas hot water heater, space heater, clothes dryer or furnace.
2. Never run your machine in an enclosed area as the exhaust from the engine contains carbon monoxide, which is a odorless, tasteless and deadly poisonous gas.
3. To reduce fire hazard, keep engine and muffler free of leaves, grass, and other debris build-up. Clean up fuel and oil spillage. Allow unit to cool at least 5 minutes before storing.
4. Before cleaning, repairing, or inspecting, make certain the tines and all moving parts have stopped. Disconnect the spark plug wire and keep wire away from spark plug to prevent accidental starting. Do not use flammable solutions to clean air filter.
5. Keep all nuts, bolts, and screws tight to be sure the equipment is in safe working condition.

6. Never tamper with safety devices. Check their proper operation regularly.
7. Do not alter or tamper with the engine's governor setting. The governor controls the maximum safe operating speed of the

engine. Over-speeding the engine is dangerous and will cause damage to the engine and to other moving parts of the machine.

<p><b>OWNER'S MANUAL</b></p> 	<p><b>SAFETY LABEL</b></p> 	<div style="text-align: center;">  <p><b>WARNING — YOUR RESPONSIBILITY</b></p> </div> <p>Restrict the use of this power machine to persons who read, understand and follow the warnings and instructions in this manual and on the machine.</p>
--	--	--

## ASSEMBLY INSTRUCTIONS

**IMPORTANT:** This unit is shipped **WITHOUT GASOLINE** or **OIL**. After assembly, see separate engine manual for proper fuel and engine oil recommendations.

### TOOLS REQUIRED FOR ASSEMBLY

- (2) 1/2" Wrenches\*
  - (1) 9/16" Wrench\*
  - (1) Pair of Pliers
- \*Two adjustable wrenches may be used.

### Loose Parts in Carton

- (1) Depth Stake
- (2) Handle Assembly
- (3) Shift Rod

**NOTE:** *Left and right is determined from the operator's position, standing behind the tiller.*

### TO REMOVE UNIT FROM CARTON

1. Remove staples, break glue on top flaps, or cut tape at carton end and peel along top flap to open carton.
2. Remove loose parts included with unit (i.e., owner's manual, etc.).
3. Cut along dotted lines and lay carton down flat.
4. Remove packing material.
5. Roll or slide unit out of carton. Check carton thoroughly for loose parts.
6. Extend control cable and lay on the floor. Be careful not to bend or kink control cable.

**NOTE:** *All hardware needed for assembly is attached to the loose parts or the tiller.*

### ATTACHING THE DEPTH STAKE ASSEMBLY

1. Tip the tiller forward so it rests on front counterweight.
2. Unthread the "T" knob from the top of the depth stake, and remove the flat washer and hex bolt. Remove the hairpin clip from the clevis pin. See figure 1.
3. Raise the tine shield hinge flap assembly. Insert the depth stake assembly in the slot (under the tine shield) and up through the tine shield assembly as shown in figure 1.
4. Insert clevis pin through the tine shield and depth stake assemblies. Secure with hairpin clip.
5. Insert hex bolt into the top hole of the depth stake assembly. Place flat washer onto the hex bolt and thread "T" knob onto the hex bolt. See figure 1. Tighten securely.
6. Tip the tiller back down so it rests on the tines.

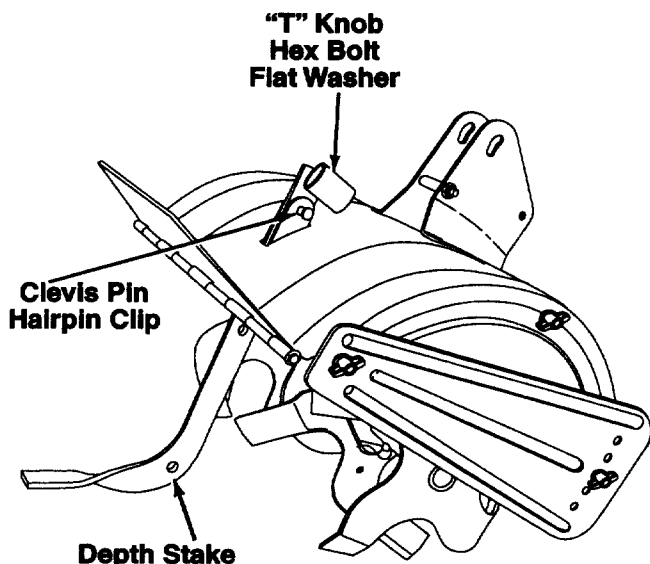

**FIGURE 1.**

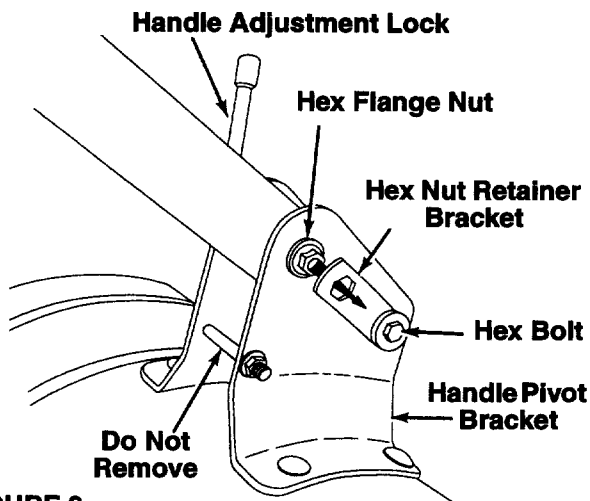

**FIGURE 2.**

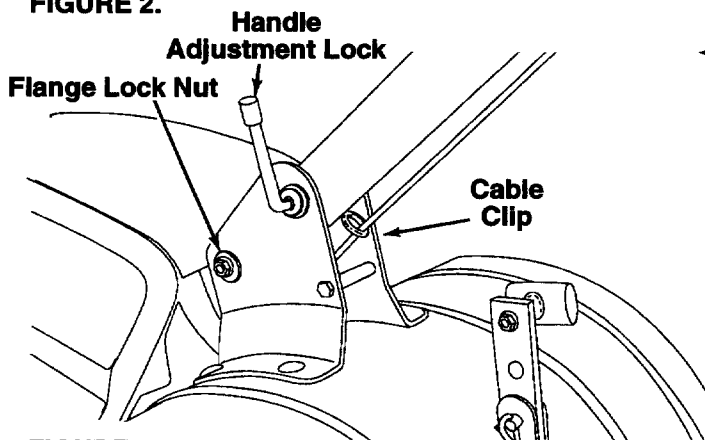

**FIGURE 3.**

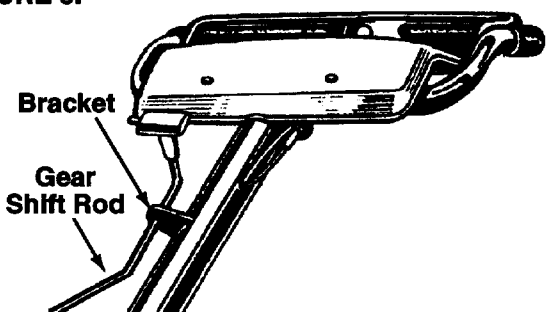

**FIGURE 4.**

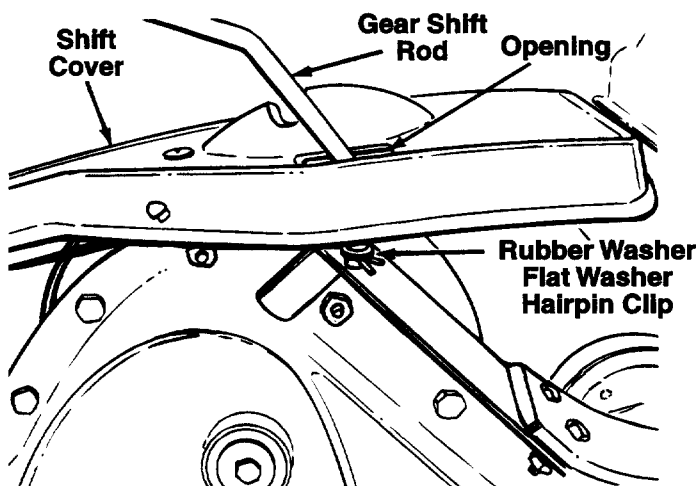

**FIGURE 5.—Viewed from Right Hand Side**

## ATTACHING THE HANDLE ASSEMBLY

1. Remove the handle mounting hardware from the handle pivot bracket. Do not remove the lower rear hex bolt and flanged lock nut. See figure 2.
2. Place the hex nut retainer bracket on the hex bolt, using the round hole in the retainer bracket.
3. Place handle assembly in position in the handle pivot bracket. Line up the holes in handle assembly with the holes (and slots) in the pivot bracket. See figure 2.
4. From the right side, insert hex bolt (with hex nut retainer attached) through bottom holes on the handle pivot bracket and handle assembly.
5. Secure the bottom of handle by placing flange lock nut on hex bolt. Do not tighten at this time. See figure 3.
6. Place the hex flange nut between the top of the hex nut retainer bracket and the pivot bracket. See figure 2.
7. Insert handle adjustment lock through handle pivot bracket and handle assembly. Thread end of handle adjustment crank into flange nut.
8. Secure the bottom hex bolt and flange lock nut.
9. Pivot handle assembly into position desired and tighten the handle adjustment lock.

## ATTACHING THE GEAR SHIFT ROD

1. Remove the hairpin clip, flat washer and rubber washer from the end of the gear shift rod. Slide the rod up through the bracket on the front of the handle assembly. Reinstall the T-handle. See figure 4.
2. Insert the end of the gear shift rod through the opening in the top of the shift cover, and into the shift bracket. See figure 5. Secure with rubber washer first, then flat washer and hairpin clip.

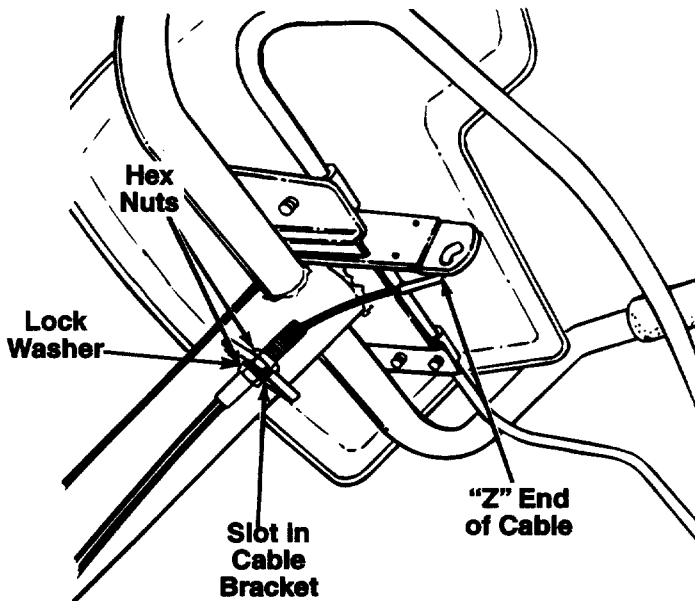

FIGURE 6.—Viewed beneath handle panel.

## ATTACHING THE CLUTCH CABLE

1. Route the clutch cable through the cable clip underneath the handle. Be careful not to bend or kink the cable. Refer to figure 3. Remove one hex nut from the threaded casing on the end of the cable. See figure 6.
2. Slip the wire through the slot on the cable bracket underneath the handle. Push the end of the casing up through the cable bracket. Rethread the hex nut on the end of the cable. Do not tighten at this time.
3. Pull the cable upwards to obtain slack, and hook the "Z" end of the cable into the bracket on the clutch control (beneath the handle panel) as shown in figure 6 (from right to left). Tighten the nut against the cable bracket.

**NOTE:** Do not overtighten control wire. Too much tension may cause it to break.

## FINAL CLUTCH ADJUSTMENT

**IMPORTANT:** Service the engine with oil and gasoline before checking this adjustment. Refer to the separate engine manual packed with your tiller.

1. Position the tiller so the front counterweight is against a solid object, such as a wall. With the gear selection lever in NEUTRAL, start the engine. Refer to Operation section.
2. Standing on the right side of the tiller, visually examine the belt (inside the belt cover). It should not be turning.

**NOTE:** Keep hands out of the belt area when unit is running.

- If the belt turns with the unit in neutral, adjust by moving the hex nut below the cable bracket down two complete turns. See figure 6. Tighten the upper hex nut against the bracket.
3. Now move the shift lever to FORWARD (Wheels Forward) position. Carefully engage the clutch by squeezing the clutch handle against the handle. The wheels should spin.
4. If the wheels do not spin with the unit in forward, adjust by moving the hex nut which is above the cable bracket up two complete turns. Tighten the bottom hex nut against the bracket.

Recheck both adjustments, and readjust as necessary. Make certain hex nuts at cable bracket are tight (do not overtighten control cable).

**NOTE:** If additional adjustment is required, it may be necessary to remove the self-tapping screws and hex nuts and flat washers to remove the belt cover, and move the hex nuts at the other end of the clutch cable to increase belt tension.

## TIRE PRESSURE

The tires on your unit may be over-inflated for shipping purposes. Reduce the tire pressure before operating the unit. Recommended operating tire pressure is approximately 12 p.s.i. (check sidewall of tire for tire manufacturer's recommended pressure).



**WARNING:** Maximum tire pressure under any circumstances is 30 p.s.i. Equal tire pressure should be maintained on both tires.

---

## CONTROLS

---

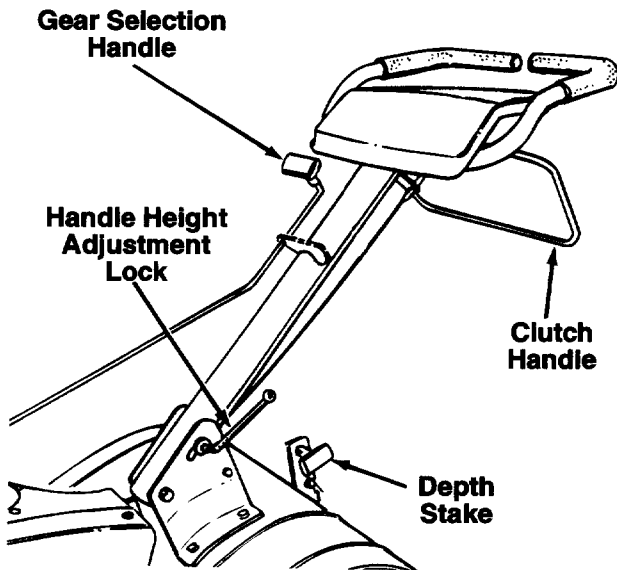

FIGURE 7.

### GEAR SELECTION HANDLE

The gear selection handle is located on the front of the handle assembly. It is used to select NEUTRAL, REVERSE, or one of the FORWARD modes.

This tiller is designed for the gear selection handle to be moved while the engine is running. (It will be difficult to obtain all four positions with the engine off.) Pull or push the handle so that the indicator on top of shift cover points to the area of the operating mode desired. See figure 7.

**NOTE:** If difficulty is encountered in moving the gear selection handle, refer to the following helpful hints.

To shift into **forward** or **reverse wheel drive**, move tiller forward slightly, then backward, to allow the gears to synchronize.

To shift into **forward wheels and tine drive**, engage the clutch handle about halfway while pushing forward on the gear selection handle, which allows the gears necessary for both drive operations to synchronize. Release the clutch handle as the gear selector moves into the proper position. Care must be taken not to fully engage the clutch.

REVERSE—Reverse wheel drive only.

NEUTRAL—Transmission is in neutral.

FORWARD Modes:

Wheels Forward— Forward wheel drive only.

Tines Reverse— Forward wheel drive and reverse tine drive.



**WARNING:** Make certain unit is in NEUTRAL when starting the engine.

### CLUTCH HANDLE

The clutch handle is located beneath the handle. See figure 7. Squeezing the clutch handle against the handle engages the wheel and tine drive mechanisms.

### THROTTLE CONTROL

The throttle control lever is located on the engine. It controls the engine speed and stops the engine. See figure 8.

### CHOKE LEVER

The choke lever is located above the throttle control. It is used to enrich the fuel mixture in the carburetor when starting a cold engine.

### DEPTH STAKE

The depth stake controls the tilling depth. Refer to "How to Use Your Tiller" section on page 7.

### HANDLE ADJUSTMENT (See Figure 7)

The handle may be adjusted to the height desired. Loosen the handle height adjustment lock a few turns. Pivot handle up or down to desired position. Tighten lock.

---

## OPERATION

---

**NOTE:** Engine is shipped *without* oil.

### BEFORE STARTING

1. **Service engine with oil** as instructed in the separate engine manual packed with your unit.
2. Fill fuel tank with clean, fresh, lead-free, low-lead or regular grade leaded gasoline.
3. Be certain to check clutch adjustment as described in final clutch adjustment in Assembly Instructions.

### TO START ENGINE

**NOTE:** When pushing the unit with the engine off, you will hear a ratcheting sound (gear noise) which is normal.



**WARNING:** Be sure no one is standing in front of the tiller while the engine is running or being started.

1. Place gear selection lever in NEUTRAL.
2. Place the throttle control lever in FAST position. See figure 8.
3. Move choke lever to CHOKE position.

**NOTE:** A warm engine may not require choking.

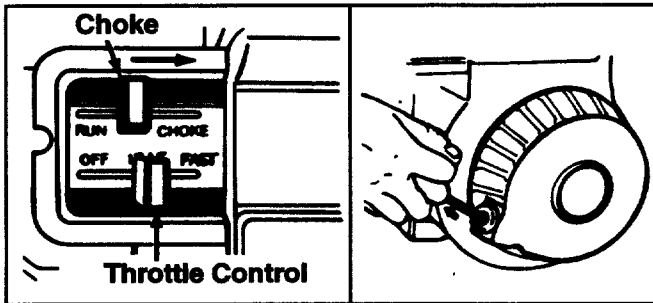

**FIGURE 8.**

4. Stand at side of tiller. Grasp the starter handle and pull out slowly, until it pulls slightly harder. Let rope rewind slowly.
5. Pull starter handle rapidly. Do not allow handle to snap back. Allow it to rewind slowly while keeping a firm hold on the starter handle.
6. Repeat steps 4 and 5 until engine starts.
7. As engine warms up and begins to operate evenly, move choke lever gradually to RUN position. If engine falters, return to choke position, then slowly move to RUN position.

Refer to engine manual for additional engine information.

### TO STOP ENGINE

1. Move throttle control to OFF position.
2. Disconnect spark plug wire and ground to prevent accidentally starting while equipment is unattended.

**NOTE:** After the first ten hours of operation, recheck the clutch adjustment. Refer to final clutch adjustment in Assembly Instructions.

## HOW TO USE YOUR TILLER



**WARNING:** When operating the tiller for the first time, use the depth stake setting that gives 1-1/2 inches of tilling depth (second hole from the top). Refer to figure 9.

Tilling depth is controlled by the depth stake which can be adjusted to five different settings. See figure 9. Adjust the side shields as shown in figure 10, as you adjust the depth stake. Be certain spark plug wire is disconnected and grounded against the engine.

1. When using the tiller for the first time, use the second adjustment hole from the top (1-1/2" of tilling depth). See figure 9.

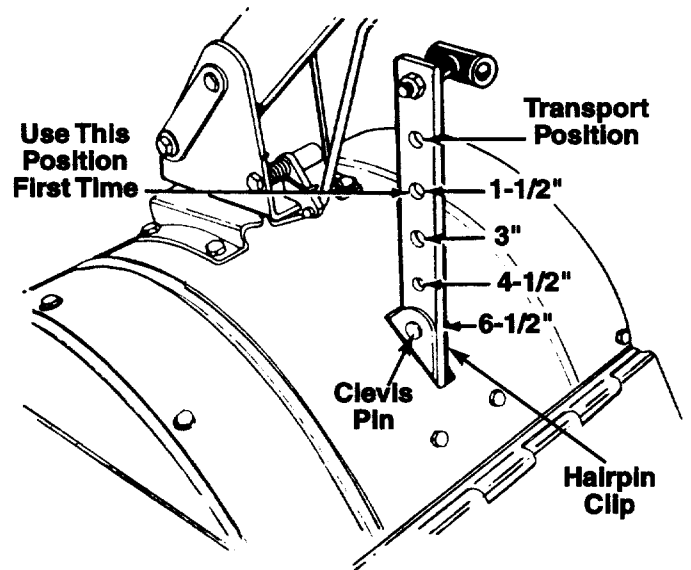

**FIGURE 9.**

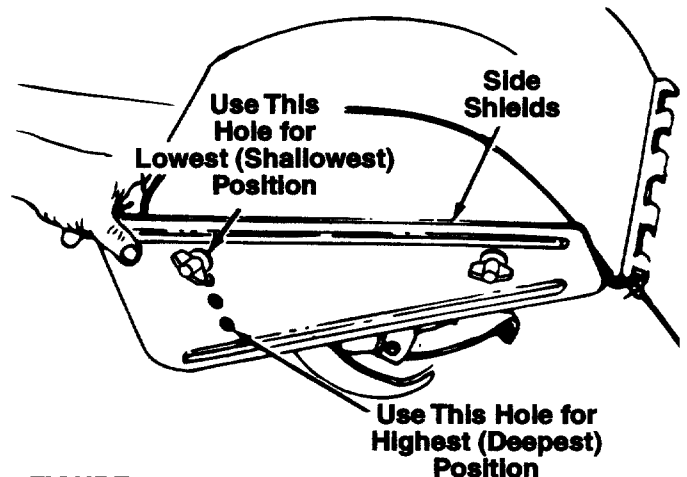

**FIGURE 10.**

2. When breaking up sod and for shallow cultivation, use the setting which gives 1-1/2" of tilling depth (second hole from the top). Place the side shields in their lowest position. For further depth, raise the depth stake and side shields and make one or two more passes over the area.
3. When tilling loose soil, depth stake may be raised to its highest position (use bottom adjustment hole) to give the deepest tilling depth. Raise the side shields to their highest position.
4. To transport tiller, lower the depth stake (use top adjustment hole).

To adjust the depth stake, remove the clevis pin and hairpin clip. See figure 9. Move the depth stake to the desired setting.

To adjust the side shields, remove the wing nuts. See figure 10. Move the side shield to the desired position. Replace wing nuts. Tighten securely.

To operate the tiller:

1. Select the depth stake setting.
2. Start engine as instructed on pages 6 and 7.
3. Move gear selection handle to one of the forward modes or reverse.



**WARNING: Do not move the gear selection handle with the wheels or tines fully engaged. Make certain the unit is stopped completely before changing the gear selection.**

4. Squeeze the clutch handle against the handle to engage the wheels and tines.

**NOTE:** Make certain the gear selection indicator is correctly positioned before engaging the clutch handle. If it is between gears, the engine will stall.

To transport tiller, **do not** engage the tines. Select the wheel drive only.



**WARNING: Do not push down on the handles so that the wheels are lifted off the ground while using the tine drive, or the tiller could move backward and cause personal injury.**

For best results, it is recommended the garden be tilled twice (lengthwise, then widthwise) to pulverize the soil.

---

## ADJUSTMENTS

---

### HANDLE ADJUSTMENT

The handle height may be adjusted. Refer to the Control section for details of handle adjustment.

### BELT TENSION ADJUSTMENT

Periodic adjustment of the belt tension may be required due to normal stretch and wear on the belt. Adjustment is needed if the tines or wheels seem to hesitate while turning, but the engine maintains the same speed.

To adjust the tension on the belt, refer to final clutch adjustment in Assembly Instructions.

### CARBURETOR ADJUSTMENT



**WARNING: If any adjustments are made to the engine while the engine is running, (e.g. carburetor), disengage all clutches and tines. Keep clear of all moving parts. Be careful of heated surfaces and muffler.**

Never make unnecessary adjustments. The factory settings are correct for most applications. If adjustments are needed, refer to the separate engine manual packed with your tiller.

---

## LUBRICATION

---

**Transmission**—The transmission is pre-lubricated and sealed at the factory. It requires no checking unless the transmission is disassembled. To fill with grease, lay the right half of the transmission on its side. Add 40 ounces of Benalene 920 grease. Assemble the left half to it. This grease can be obtained at your nearest authorized dealer. Order part number 737-0300.

**Clutch Handle**—Lubricate the pivot point on the clutch handle and the cable at least once a season with light oil. The control must operate freely in both directions.

**Pivot Points**—Lubricate all pivot points and linkages at least once a season with light oil.

**Tine Shaft**—Remove tines and lubricate tine shaft at least once a season with light oil.

**Wheel Shaft**—Remove wheel assemblies and lubricate at least once a season.

---

## MAINTENANCE

---



**WARNING: Disconnect the spark plug wire and ground it against the engine before performing any repairs or maintenance.**

### ENGINE

**Refer to the separate engine manual for engine maintenance instructions.**

Maintain **engine oil** as instructed in the separate engine manual packed with your unit. Read and follow instructions carefully.

Service **air cleaner** every ten hours under normal conditions. Clean every hour under extremely dusty conditions. Poor engine performance and flooding usually indicates that the air cleaner should be serviced. To service the air cleaner, refer to the separate engine manual packed with your unit.

**IMPORTANT:** Never run your engine without air cleaner completely assembled.

The **spark plug** should be cleaned and the gap reset every 25 hours of engine operation. Spark plug replacement is recommended at the start of each tiller season; check engine manual for correct plug type and gap specification.

**Clean the engine** regularly with a cloth or brush. Keep the cooling system (blower housing area) clean to permit proper air circulation which is essential to engine performance and life. Be certain to remove all dirt and combustible debris from muffler area.

### CLEANING THE TINE AREA

Clean the underside of the tine shield after each use. The dirt washes off the tines easier if washed off immediately instead of after it dries.



## TIRES

Recommended operating tire pressure is approximately 12 p.s.i. (check sidewall of tire for tire manufacturer's recommended pressure). Maximum tire pressure under any circumstances is 30 p.s.i. Equal tire pressure should be maintained on both tires.

When installing a tire to the rim, be certain rim is clean and free of rust. Lubricate both the tire and rim generously. Never inflate to over 30 p.s.i. to seat beads.



**WARNING:** Excessive pressure (over 30 p.s.i.) when seating beads may cause tire/rim assembly to burst with force sufficient to cause serious injury.

## BELT REPLACEMENT



**CAUTION:** Do not use an off-the-shelf belt.

Your tiller has been engineered with a belt made of special material (Kevlar Tensile) for longer life and better performance. It should not be replaced with an off-the-shelf belt.

If belt replacement is required, order belt or belts by part number from your nearest authorized dealer.

Part No. 754-0438—"V" Belt

1. Disconnect and ground the spark plug wire against the engine.
2. Remove the belt cover from the left side of the tiller as follows.
  - a. Remove two torx head screws from the top of belt cover.
  - b. Remove two hex cap nuts and flat washers from front side of the belt cover. Remove the hex cap nut and flat washer at the back of the cover.
3. Remove the belt keeper assembly located behind the engine pulley by removing two hex bolts and lock washers. See figure 11.
4. Remove belt. Reassemble new belt, following instructions in reverse order.

**NOTE:** Upon reassembly, make certain the belt is routed over the idler pulley and inside of belt keepers by engine pulley. See figure 11.

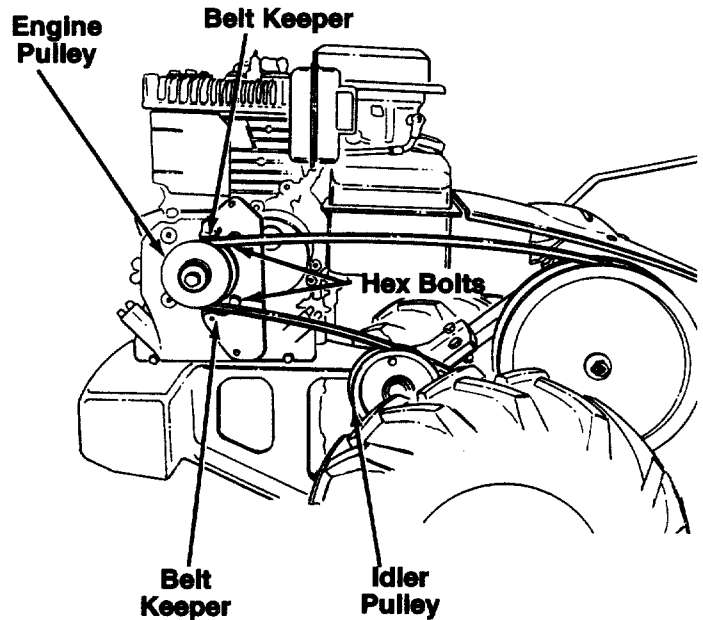

FIGURE 11.

---

## OFF-SEASON STORAGE

---

If the tiller will not be used for a period longer than 30 days, the following steps should be taken to prepare the tiller for storage.

1. Clean the exterior of engine and the entire tiller thoroughly. Lubricate the tiller as described in the lubrication instructions.
2. Refer to the engine manual for correct engine storage instructions.
3. Wipe tires with oiled rag to prevent rust.
4. Store tiller in a clean, dry area. Do not store next to corrosive materials, such as fertilizer.

**NOTE:** When storing any type of power equipment in an unventilated or metal storage shed, care should be taken to rustproof the equipment. Using a light oil or silicone, coat the equipment, especially any springs, bearings and cables.

# TROUBLE SHOOTING GUIDE

Trouble	Possible Cause(s)	Corrective Action
Engine fails to start	<ol style="list-style-type: none"> <li>1. Cold engine not choked.</li> <li>2. Fuel tank empty, or stale fuel.</li> <li>3. Throttle control lever not in starting position.</li> <li>4. Spark plug wire disconnected.</li> <li>5. Faulty spark plug.</li> <li>6. Engine flooded.</li> </ol>	<ol style="list-style-type: none"> <li>1. Move choke lever to CHOKE position.</li> <li>2. Fill tank with clean, fresh gasoline.</li> <li>3. Move throttle lever to FAST position.</li> <li>4. Connect wire to spark plug.</li> <li>5. Clean, adjust gap or replace.</li> <li>6. Crank engine with throttle in FAST position.</li> </ol>
Engine runs erratic	<ol style="list-style-type: none"> <li>1. Unit running on CHOKE.</li> <li>2. Spark plug wire loose.</li> <li>3. Stale fuel.</li> <li>4. Vent in gas cap plugged.</li> <li>5. Water or dirt in fuel system.</li> <li>6. Dirty air cleaner.</li> <li>7. Carburetor out of adjustment.</li> </ol>	<ol style="list-style-type: none"> <li>1. Move choke lever to OFF position.</li> <li>2. Connect and tighten spark plug wire.</li> <li>3. Fill tank with clean, fresh gasoline.</li> <li>4. Clear vent.</li> <li>5. Drain fuel tank. Refill with fresh fuel.</li> <li>6. Clean air cleaner as instructed in separate engine manual.</li> <li>7. Adjust carburetor as instructed in separate engine manual.</li> </ol>
Engine overheats	<ol style="list-style-type: none"> <li>1. Engine oil level low.</li> <li>2. Air flow restricted.</li> <li>3. Carburetor not adjusted properly.</li> </ol>	<ol style="list-style-type: none"> <li>1. Fill crankcase with proper oil.</li> <li>2. Remove blower housing and clean as instructed in separate engine manual.</li> <li>3. Adjust carburetor as instructed in separate engine manual.</li> </ol>
Tines do not engage	<ol style="list-style-type: none"> <li>1. Foreign object lodged in tines.</li> <li>2. Tine clevis pin(s) missing.</li> <li>3. Control cable not adjusted properly.</li> <li>4. Belt worn and/or stretched.</li> </ol>	<ol style="list-style-type: none"> <li>1. Dislodge foreign object.</li> <li>2. Replace tine clevis pin(s).</li> <li>3. Adjust control cable (see Adjustment Section).</li> <li>4. Replace belt.</li> </ol>
Wheels do not engage	<ol style="list-style-type: none"> <li>1. Control cable not adjusted properly.</li> <li>2. Belt worn and/or stretched.</li> </ol>	<ol style="list-style-type: none"> <li>1. Adjust control cable (see Adjustment Section).</li> <li>2. Replace belt.</li> </ol>

NOTE: For repairs beyond the minor adjustments listed above, please contact your local service dealer.

# TILLER

## ASSORTED PARTS LIST

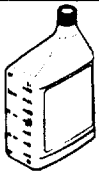
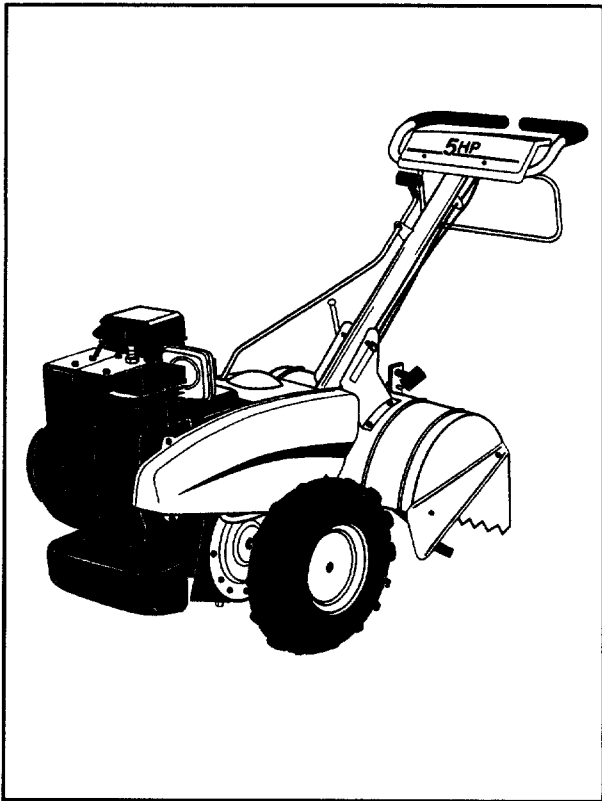

**Engine Oil (SAE 30)**  
Part No. 737-0208



**Clutch Control Cable**  
Part No. 746-0916



**V-Belt**  
Part No. 754-0438

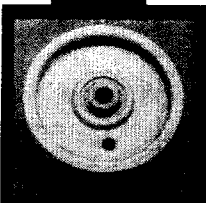

**Idler Pulley**  
Part No. 756-0405



**Tine Blades**  
Part No. 642-0015 L.H.  
Part No. 642-0016 R.H.

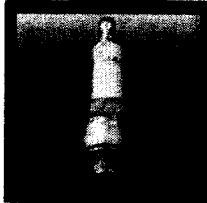

**Spark Plug**  
RJ19LM

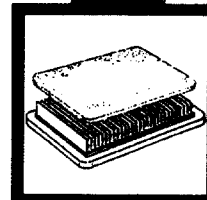

**Pre Cleaner B&S 491435**  
**Air Cleaner B&S 491588**

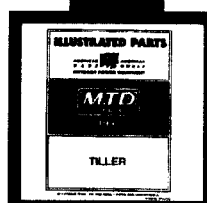

**Illustrated Parts Manual**  
Part No. 770-97-6B

For Parts, Accessories or Service Information,

# Call 1-800-800-7310

Copy the  
information from  
your model  
plate here:

Model Number										
<input type="text"/>	<input type="text"/>	<input type="text"/>	<input type="text"/>	<input type="text"/>	<input type="text"/>	<input type="text"/>	<input type="text"/>	<input type="text"/>	<input type="text"/>	<input type="text"/>
Serial Number										
<input type="text"/>	<input type="text"/>	<input type="text"/>	<input type="text"/>	<input type="text"/>	<input type="text"/>	<input type="text"/>	<input type="text"/>	<input type="text"/>	<input type="text"/>	<input type="text"/>
Product Number										
<input type="text"/>	<input type="text"/>	<input type="text"/>	<input type="text"/>	<input type="text"/>	<input type="text"/>	<input type="text"/>	<input type="text"/>	<input type="text"/>	<input type="text"/>	<input type="text"/>
May not fill all the above spaces										

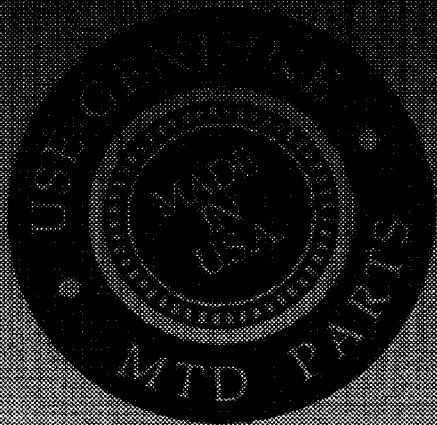

The only way to ensure the performance of your product is to use original equipment parts and accessories. MTD designs and engineers quality parts to exacting specifications. When you substitute, you take a chance on quality, reliability, safety and performance. Use MTD original equipment,  
the best buy on the American Landscape.  
**-American Made American Owned -**



**WARNING:** The Engine Exhaust from this product contains chemicals known to the State of California to cause cancer, birth defects or other reproductive harm.